

# Design and Determination of Optimum coefficients of High-Q IIR Notch Filter

Subhadeep Chakraborty<sup>1</sup>, Abhishek Dey<sup>2</sup>, Kushal K. Saha<sup>3</sup>, Nabanita Dutta<sup>4</sup>

Lecturer, Technique Polytechnic Institute, Hooghly, West Bengal, India<sup>1,2</sup>

Project Fellow, Technique Polytechnic Institute, Hooghly, West Bengal, India<sup>3,4</sup>

**Abstract:** In Digital Signal Processing, there are different applications are found for Filters. The filters are categorised and designed as IIR filter or FIR filter for different applications dependent upon impulse response. In this paper a notch filter is designed of high quality factor to cut specifically 100Hz. This notch frequency is chosen because at that frequency some noise may be observed or harmonics of the main signal may be observed that can be referred as the noise. To stop or notch those type of noise and as the frequency standard for main electricity is 50Hz, the corresponding suitable Notch filter is designed which perfectly cut 100Hz frequency without using any amplification device. The simulations are done on the IIR Notch Filter and the result shows that the analog filter, that is designed from which the IIR filter is designed is highly accurate in specification of components and other required parameters which is reflected in the coefficient values.

**Keywords:** IIR Filter, Notch filter, Digital filters, analog to digital mapping, coefficients.

## I. INTRODUCTION

In Signal Processing system, filter is required to process the signal of desired band of frequencies. If there is a requirement of declining a bands of frequency and thereby pass all other frequencies, the band stop filter is essentially required. In this case let we have  $f_1, f_2, f_3, \dots, f_{n-1}, f_n$  band of frequencies and the band  $f_r, \dots, f_{k-1}$  have to be stopped. So to perform this specific operation, band stop filter will have to be used. But if only one frequency will have to be stopped, the special type of band stop filter that is the Notch filter will be in use.[1][2][3][4][5][22][24].

The passive components such as the resistors, capacitors etc are generally used to construct the passive filters. That will be analog in construction type. Actually filter is a device and so it must have a transfer function and after Laplace transform of this, the transfer function in s-domain can be achieved[2][3][4][5][22][24][26]. After getting the s-domain function, the order of the filter can be determined[3][4][5][23][25][26]. The order of the filter is essential to determine the characteristic of the system of filtration technique. A high order filter is nearly behaves like an ideal filter. The so generated filter equation can be observed in frequency domain[4][5][6][8][24][25]. If it is required to view the stability and the pole and zeros of the system more accurately, the Z-Transform is required. The generated filter with ZT values and transfer function can be defined as the Digital Filter [3][5][7][8][10] [13][22] [25][26]. Now the Z-Transform of the analog filter can be obtained either by taking the input and output values in transformed version and thereby generating the transfer function in the digital plane or perform the analog to digital mapping technique to convert the analog transfer function to its equivalent digital transfer function directly. There are a number of techniques are available for analog to digital mapping technique and hence the Bilinear Transformation technique is applied in this paper for the design of a digital filter.[2][4][5][8][7][12][25][26].

The Notch filter is designed both in hardware and software means. First the filter is designed in software means in National Instrument's Multisim v12 and after successful simulation, the circuit is designed with components. A new concept is incorporated in this design by applying Electrolytic Capacitor at the ground node which helps for the notching of perfect 100Hz.

The Notch filter is of mainly two types, High Pass Notch filter and Low Pass Notch filter depending upon the passband and stopband frequency. Depending upon the Notch bandwidth, Notch filter can be categorized as Wideband Notch Filter and Narrowband Notch Filter. If it is required to stop a single frequency, the narrow band notch filter is essentially required. In this paper the design is proposed for a Narrowband Notch filter which is employed to stop 100Hz

## II. PREVIOUS WORK

There different works and experiments were visualized on behalf of the Notch Filter specially on the emphasis of varying the Q factor and minimizing the noise[1][4][5][6][9][10][25][26]. Frey, D.R and Steigerwald, L. works on the Notch for adaptive control on it which requires very high frequencies[6]. The analogous work was proposed by Ye Wu, Yongge Wan and Yingqiu Li for adaptive filter design in data processing[1]. Qiusheng Wang and Deepa Kundur have proposed the design of multiple notch filter[24]. Erwin H. W. Chan and Robert A. Minasian have proposed a design to use the notch filter in RF frequency[25]. So, regarding to the notch filter and notching the required or selected frequency with determination of quality factor and thereby introducing the quality of efficiency have been proposed. Our previous works reveals the outcome the coefficients determination and design of digital filters using DTA[2][3][4][5][8][22][23][24].

This algorithm efficiently maps the analog filter into digital plane i.e. the z-plane through which the stability can be determined. The stability can also be determined by Bode Plot. The stability of a filter is essentially required to determine the operational performance of it. The quality factor or Q-factor is also a required parameter to make understand the notch depth. All the parameters are discussed in the preceding section with the simulation result and the table of values.

### III. PROPOSED DESIGN OF NOTCH FILTER

The Notch filter can be designed using different topologies either by using operational amplifier or without using the operational amplifier. The widely known topology that is generally used for the design of the notch filter is the Twin-T topology. In this topology, the resistance and capacitance are used. By calculating the values of the resistance and capacitance, the desired value of Notch frequency can be determined.

The design parameters are so calculated that it must be a Narrowband Notch filter which effectively rejects the 100Hz. As the bandwidth is very small, the quality factor is very high. The values of resistance and capacitance are chosen in such a way that the attenuation is lower and so the determination of order is easier and thus the filter is operated efficiently.

The proposed circuit is designed using National Semiconductor Multisim v 12.0. The design is shown below.

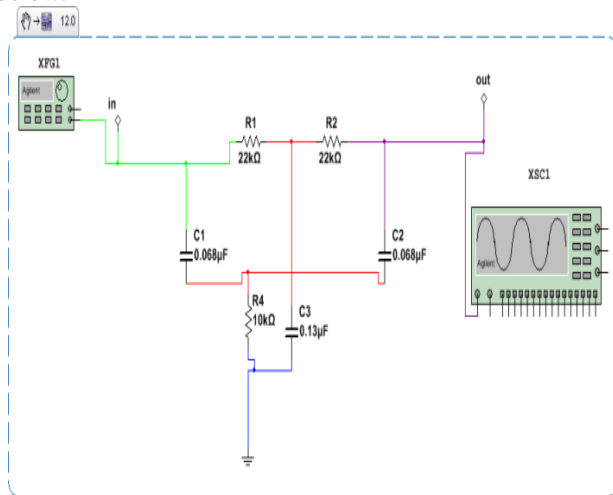

Fig.1 Proposed design of 100Hz Notch

In this proposed design, the following parameter strategies are used as generally designed for Twin-T topology,

- $R1=R2$
- $R4=\frac{1}{2}R1=\frac{1}{2}R2$
- $C1=C2$
- $C3=2C1=2C2$

In this design, a function generator(XFG1) is connected at the input terminal to provide the input signal. The input voltage is fixed at 50 mVpp. The frequency is increased from 40Hz to 130 Hz. The output waveform is observed at the CRO (XSC1) where it is observed that for varying

the input frequency, the magnitude is falling towards zero till 96 Hz and after near about 103Hz again the magnitude is increasing. So, from this design, it can be said that the Notch filter nearly cuts 100Hz.

### IV. CALCULATION OF Q-FACTOR

The Q-Factor or Quality factor of a notch filter determines the notch depth and the order of it. The notch filter has two cutoff frequencies, low cutoff frequency( $f_l$ ) and high cutoff frequency( $f_h$ ). The difference between these two cutoff frequencies is referred as the Bandwidth of the rejected region. In Notch filter, there must be a selected frequency to which the designed must concentrate for rejection. This frequency is called the Notch frequency. The quality factor is the ration of the notch frequency to the bandwidth. So, for high quality factor signifies lessen bandwidth. The bandwidth of the Notch filter is defined by,

$$BW = f_h - f_l \quad \text{.....(1)}$$

This bandwidth is essentially required to calculate the quality factor, expressed by,

$$Q = \frac{f_{notch}}{BW} \quad \text{.....(2)}$$

Where,

$BW$  = Bandwidth

$f_{notch}$  = Notch frequency

$f_h$  = High cutoff frequency

$f_l$  = Low cutoff frequency

Now the above parameters is to be calculated from the output taken from oscilloscope. Actually, the oscilloscope produces the output voltage that is generated by the Notch filter circuit. The  $V_{out}$  is calculated with  $V_{in}$  for the design of Gain. When the gain is plotted, the HPBW is found which is actually -3dB point of the gain plot. In notch filter there will be two points of -3dB(0.707) which signifies two cutoff frequencies( $f_l$  &  $f_h$ ). When the cutoff frequencies are found, the bandwidth can be calculated and thereby the quality factor can be found. The calculations are shown in the preceding section by plotting the magnitude response.

#### A. Magnitude Response

The circuit shown in Fig.1, produces output such that it will response zero voltage output at our desired frequency i.e. 100Hz that means it will produce the characteristic of a notch filter. The values taken from the experimental result are shown below table.

In the above experiment, 50 readings were taken from 1Hz to 185 Hz. The input voltage is fixed at 50 mVpp and thereby the circuit produces the output voltage at those frequencies. The input is provided by the function generator which is sinusoidal in type. The output observed at the oscilloscope. After getting all the output values of the circuit it is seen that at 100Hz, this circuit produces no output that is at that frequency, the signal is Notched or rejected. The gain is calculated with respect to the  $V_{in}$  &  $V_{out}$  and the Gain vs. Frequency plot is shown below.

Table 1: Results of Notch Filter

Sl. No.	Vin(Mv)	Frequency(Hz)	Vout(mV)
1	50	1	49.8
2	50	5	48.5
3	50	10	47.00
4	50	15	43.50
5	50	20	40
6	50	25	36.15
7	50	30	31.05
8	50	35	29.00
9	50	40	25.00
10	50	45	22.50
11	50	50	17.5
12	50	55	15.00
13	50	60	12.50
14	50	65	11.25
15	50	70	10.00
16	50	75	08.75
17	50	80	07.50
18	50	85	06.25
19	50	90	03.75
20	50	95	02.50
21	50	96	02.50
22	50	97	01.50
23	50	98	01.00
24	50	99	00.50
25	50	100	00.00
26	50	101	00.16
27	50	102	00.25
28	50	103	00.75
29	50	104	01.50
30	50	105	02.50
31	50	106	03.00
32	50	107	03.75
33	50	108	06.00
34	50	109	07.80
35	50	110	08.70
36	50	115	10.00
37	50	120	11.25
38	50	125	12.30
39	50	130	15.00
40	50	135	17.50
41	50	140	22.00
42	50	145	25.00
43	50	150	29.00
44	50	155	31.05
45	50	160	36.15
46	50	165	40
47	50	170	43.50
48	50	175	47.00
49	50	180	48.5
50	50	185	49.8

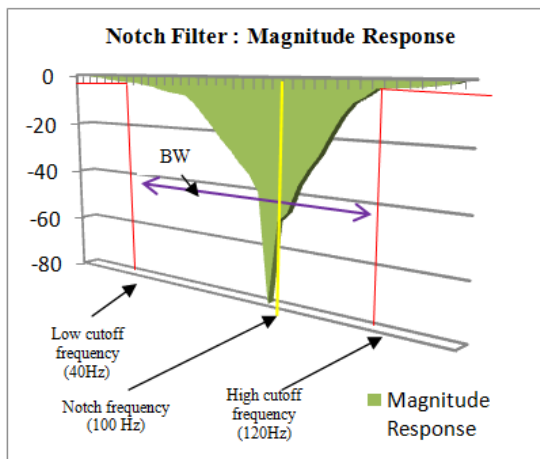

Fig. 2 Magnitude Response of Proposed Notch Filter

This magnitude response shows two cutoff frequencies,  $f_l$  &  $f_h$  with 40Hz & 120 Hz respectively. From these two values, the bandwidth and the quality factor will be calculated in the preceding section.

**B. Quality Factor**

As the magnitude response shows with respect to the values taken from the circuit,

$$f_l = 40\text{Hz}$$

$$f_h = 120\text{Hz}$$

So, the bandwidth will be,

$$BW = (120 - 40) \text{ Hz} = 80 \text{ Hz}$$

The quality factor will then be calculated for

$$f_{notch} = 100\text{Hz by,}$$

$$Q = \frac{f_{notch}}{BW} = \frac{100}{80} = 1.25$$

Now in our experiment, as the bandwidth is produced by 80Hz, so the quality factor is calculated as 1.25. If the bandwidth will be narrower by varying the values of the components or by changing the parameters, the quality factor will be improved more and more and that will be shown in our preceding papers.

Now this Notch filter can be well realized if it is mapped into digital plane where all the required quantities can be found such as the pole-zero value, phase response, magnitude response etc. The design of the digital filter is shown in the preceding section.

**V. REALIZATION OF IIR DIGITAL NOTCH FILTER**

IIR Filter has a network or system which is of recursive type. Such recursive system can be described by the following Difference equation where  $x(n)$  is the input of the system and  $y(n)$  is the output of that system[8][16][17][22][23][25],

$$y(n) = -\sum_{k=1}^N a_k y(n-k) + \sum_{k=0}^M b_k x(n-k)$$

$$y(n) = -a_1 y(n-1) - a_2 y(n-2) \dots - a_{N-1} y(n-N+1) - a_N y(n-N) + b_0 x(n) + b_1 x(n-1) \dots + b_M x(n-M) \dots (3)$$

Let,  $w(n) = b_0 x(n) + b_1 x(n-1) \dots + b_M x(n-M)$  .....(4)

Equation (3) can be represented as,

$$y(n) = -a_1 y(n-1) - a_2 y(n-2) \dots - a_{N-1} y(n-N+1) - a_N y(n-N) + w(n) \dots (5)$$

Now taking the Z-Transform in the both sides of equation (3), we get

$$Y(z) = -a_1 z^{-1} Y(z) - a_2 z^{-2} Y(z) \dots - a_{N-1} z^{-(N-1)} Y(z) - a_N z^{-N} Y(z) + b_0 X(z) + b_1 z^{-1} X(z) \dots + b_M z^{-M} X(z) \dots (6)$$

Rearranging the equation (6), we get,

$$Y(z) = -(a_1z^{-1} + a_2z^{-2} + \dots + a_{N-1}z^{-(N-1)} + a_Nz^{-N})Y(z) + (b_0 + b_1z^{-1} + \dots + b_Mz^{-M})X(z) \quad \dots(7)$$

So, from the Equation (3) it is clear that in a IIR system, the present output depends upon the past inputs and the past outputs. Now taking the Z-Transform of Equation (3) the structure of the IIR Filter can be determined with the application of Direct form-I Realization. This method is used to separate delays for both input and output. This realization requires M+N+1 multiplications, M+N additions and M+N+1 memory locations[22][24][25][26]. The structure of Direct form – I realization for an IIR Filter described in equation (3) is shown in Fig.3[ 8][16][19][24][25][26].

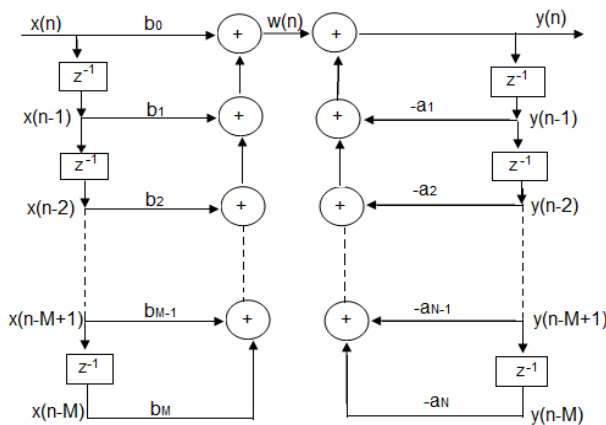

Fig.3 Direct Form-I realization of IIR Digital filter

After successful realization of the design analog filter through Direct Form-I realization technique, the analog filter is mapped or transformed into digital plane. Here x(n) denotes for discrete form input of the filter and y(n) is the discrete form of output from the filter. The transfer function is to be designed from these two parameter which is shown in preceding section.

## VI. REALIZATION OF TRANSFER FUNCTION IN DIGITAL PLANE

The impulse response is actually the ratio of the produced output to the given input, that is more elaborately, the transfer function H(z) is actually the ratio of the Z-Transform of output to the input.

The impulse response h(n) for a realizable filter is[8][16][22][25],

$$h(n) = 0 \text{ for } n \leq 0 \quad \dots(8)$$

where h(n) must satisfy the following condition to ensure the stability of a filter[8][16],

$$\sum_{n=0}^{\infty} |h(n)| < \infty \quad \dots(9)$$

Now, the Z-Transform of the impulse response h(n) i.e. H(z) is referred to as the transfer function of a digital filter. So, our interest goes to the determination of the H(z) because the H(z) contains the numerator and denominator

coefficients which are essentially required to design the Digital filter.

Now to determine the transfer function of the IIR filter, we rewrite the equation (7) and get the required H(z) equation,

$$H(z) = \frac{\sum_{n=0}^M b(n)z^{-n}}{1 + \sum_{n=1}^N a(n)z^{-n}} \quad \dots(10)$$

$$= \frac{B(z)}{A(z)} = \frac{b(0) + b(1)z^{-1} + b(2)z^{-2} + \dots + b(M)z^{-M}}{1 + a(1)z^{-1} + a(2)z^{-2} + \dots + a(N)z^{-N}} \quad \dots(11)$$

Where,

b(n) = Numerator coefficient of the filter

a(n) = Denominator coefficient of the filter

H(z) = Y(z) / X(z) = B(z) / A(z) = Transfer function

After successful determination of the transfer function, we can calculate the coefficients of the filter i.e. the determination of b(n) and a(n). Actually the Transfer Function refers that for giving some input how much output can be obtained. There are various techniques available to design and calculate the coefficients of an IIR Digital Notch filter.

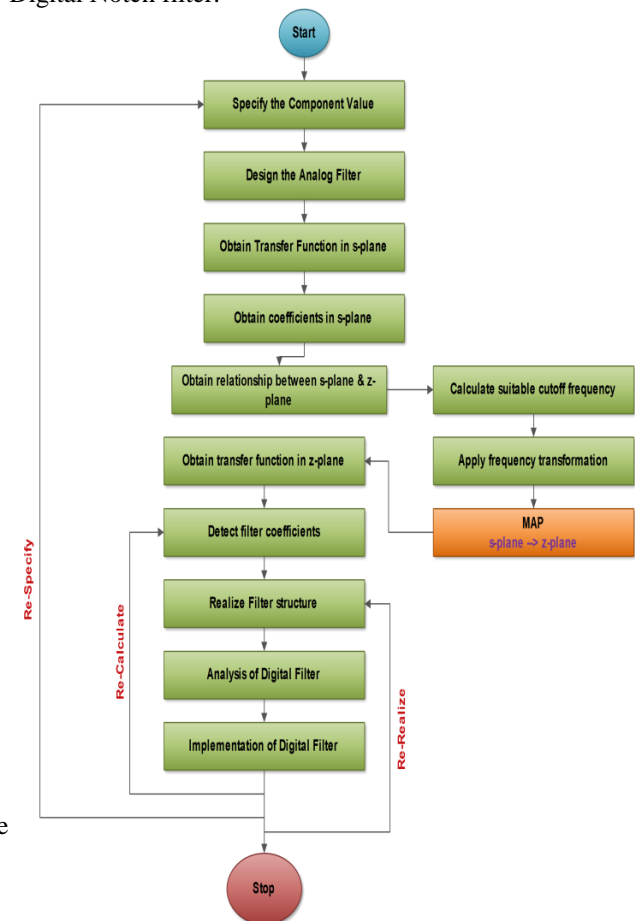

Fig.4 Domain Transfer Algorithm

The algorithm referred here can be used for smarter determination of IIR Digital Notch filter and is much more helpful for the determination of the transfer function as well as the coefficients. The algorithm is referred to as

DTA(Domain Transfer Algorithm)[22][23][24][25][26]. The flowchart of the algorithm is shown below in Fig.4.

So after selection of proper parameter values, the Notch filter can be designed by DTA with proper order. In our design, the designed Notch filter when mapped into z-plane, produces an order of 6. Our objective is to design a Notch filter of higher quality factor without deteriorating the order of filter. The simulation result of the Notch filter using DTA are shown in the following section.

### VII. SIMULATION RESULT

In the previous sections, the design of the Notch filter is presented along with its realization in digital plane. The digital plane or z-plane actually shows the stability of the filter. These require typical simulation of different quantities such as the magnitude response, impulse response, pole zero plot and the phase response. The IIR Notch filter is simulated in Matlab 7(R2008a) and the results are shown below.

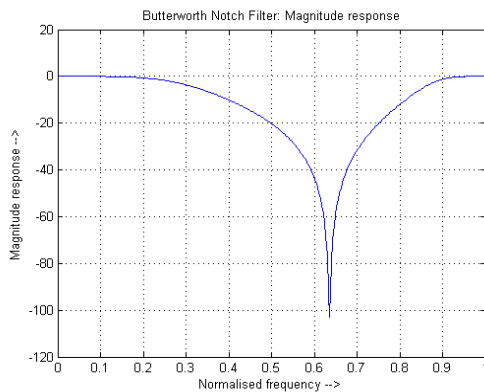

Fig. 5 Magnitude Response

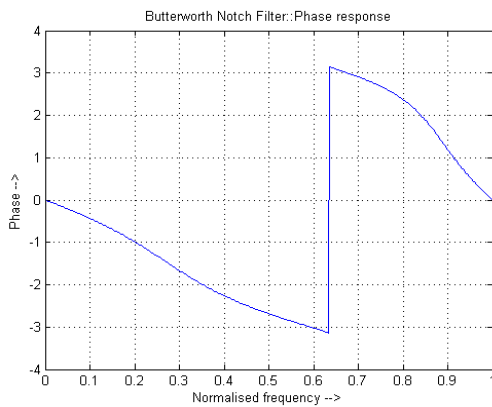

Fig. 6 Phase Response

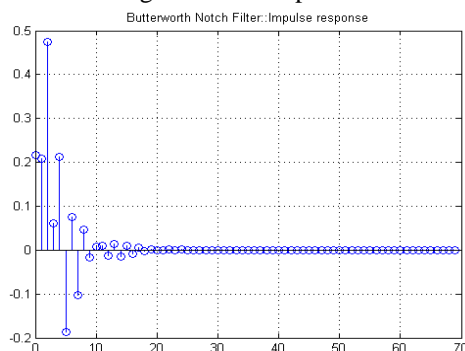

Fig. 7 Impulse Response

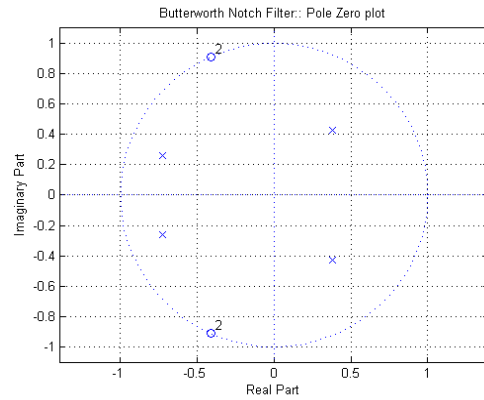

Fig. 8 Pole-Zero Plot

The simulation is done by transforming the analog transfer function of the Notch filter into the digital plane. The parameter is so chosen that the filter response with the order of 4 but it satisfactorily generates a quality factor of 1.5. Generally, the order is chosen or determined by the values of the parameter values but in that case the order may not be the same while determining different quality factors. But in this case the quality factor is increased which is not dependent of the order as at the ground section an Electrolytic capacitor is connected which actually stores the charges in ionic form for which the charge in that becomes stable and same for the order. This is the main advantage of our design. In this design the noise power is minimized. The noise power is solely responsible for deteriorating the order and performance of the filter. As it is minimized up to the level best, the designed Notch filter becomes more stable and is operated efficiently. These simulation results along with the coefficient values and the transfer functions are shown below.

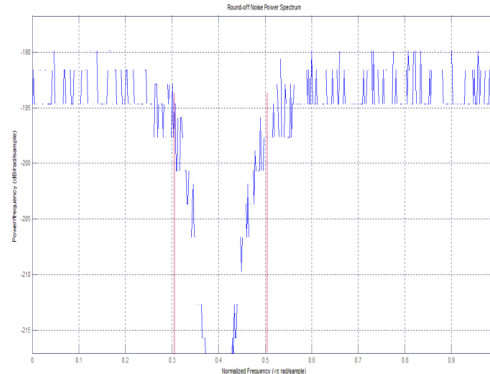

Fig. 9 Round off Noise power spectrum

The coefficients of the designed Notch filter of order 4 with Q-Factor 1.5 are given below.

Table-2 Coefficient Values

Numerator Coefficients	Denominator Coefficients	Order	Gain
0.5136 - 0.7683 0.7753 - 0.365 0.1159	1 - 3.454 4.585 - 2.305 0.4132	4	2.323618494293 2789
<b>Transfer Function</b>	$\frac{0.5136 z^4 - 0.7683 z^3 + 0.7753 z^2 - 0.365 z + 0.1159}{z^4 - 3.454 z^3 + 4.585 z^2 - 2.305 z + 0.4132}$		



## VIII. CONCLUSION

In this paper the designed analog filter is transformed into digital plane and realized by Direct Form-I technique. After that, the digital filter is designed with Butterworth technique such that the stop band and pass band ripple can be minimized. After successful design of the Notch Filter, the output results are shown in the Simulation section. From the simulation files particularly from the pole zero plot, it can be said that the designed filter is stable and from the simulation result from the experiment through Fig.2, it can be said that the design filter is of Q-Factor 1.5.

## ACKNOWLEDGMENT

The design of the Notch filter is first done in Multisim provided by National Instrument in version 12. The software shown the output of the circuit. When the output is satisfactory, the passive hardware components are used for the design and again the results are taken from Oscilloscope and the Gain vs. Frequency is plotted and thereby the quality factor is calculated. To determine the stability the analog filter is transformed into digital plane. The digital filter i.e. the IIR Notch filter is realized by Direct Form-I technique through Butterworth method to minimize ripple. The simulations of the digital filter are done using Matlab 7 and those are shown. For the analog to digital mapping technique, DTA is used for efficient mapping.

## REFERENCES

- [1] Kota Solomon Raju, Y.Pratap, Virendra Patel, S.M.M Naidu, Amit,Patwardhan and P.Bhanu Prasad, "Digital Multichannel GPS Receiver Baseband Modules using Model Based Design Tools" International Journal of Mobile Network Communications & Telematics (IJMNCT) Vol.2, No.4, August 2012
- [2] Behzad Razavi, *Fellow, IEEE*, "Cognitive Radio Design Challenges and Techniques", IEEE Journal of Solid-State circuits, vol. 45, no. 8, August 2010
- [3] Asad A. Abidi, *Fellow, IEEE*, "The Path to the Software-Defined Radio Receiver", IEEE Journal of Solid-State circuits, vol. 42, no. 5, may 2007
- [4] Subhadeep Chakraborty, Krishna Kumar Jha, Abhirup Patra, "Design of IIR Digital Highpass Butterworth Filter using Analog to Digital Mapping Technique", International Journal of Computer Applications (0975 – 8887) Volume 52 – No. 7, August 2012
- [5] Ranjit Singh and Sandeep K. Arya, "Determining Optimum coefficients of IIR Digital Filter using Analog to Digital Mapping," International Journal of Advancements in Computer Science and Information Technology, Vol. 01, No. 01, September 2011 pp.19-23.
- [6] R.S. Chauhan and Sandeep K. Arya, "Design of IIR digital filter using analog to digital mapping", Journal of Neural Computing Systems, Vol. 03, No. 01, 2010, pp. 51-55.
- [7] Ranjit Singh Chauhan and Sandeep Kumar Arya, "Determine Optimal Coefficients of IIR Digital Filters using Simulated Annealing", International Journal of Computer Applications (0975 – 8887) Volume 43– No.10, April 2012 36
- [8] P. Ramesh Babu, "Digital Signal Processing", Fourth edition, Scitech Publication (India) Pvt. Ltd, Chennai, 2008.
- [9] Ramakant A. Gayakwad, "Opamp and Linear Integrated Circuit", Fourth Edition, PHI Learning Private Limited, New Delhi, 2010.
- [10] A. Sudhakar and Shyammoan S. Palli, "Circuits and Network", Fourth Edition, TataMcGraw Hill Education Private Limited, New Delhi, 2011.
- [11] D. Chattopadhyay and P.C. Rakshit, "Fundamentals of Electric Circuit Theory", S.Chand & Company Ltd. 2006.
- [12] Johannes Innerbichler, *TU Graz*, Achim Schweighofer, *TU Graz*, "Comparison of Characteristics

- of FIR and IIR Filter", Journal of LATEX class filters, vol. 6, no. 1, January 2007.
- [13] Gurleen Kaur and Ranjit Kaur, "Design of Recursive digital filters using Multiobjective Genetic algorithm", Gurleen Kaur et al. / International Journal of Engineering Science and Technology (IJEST), ISSN : 0975-5462 Vol. 3 No. 7 July 2011.
- [14] Sangeetha Marikkannan, Leelavathi, Udhayasuriyan Kalaiselvi, Kavitha, "Scheduling and Allocation Algorithm for an Elliptic Filter", International Journal of Advanced Information Technology (IJAIT) Vol. 2, No.2, April 2012
- [15] Nagendra Krishnapura, Abhishek Agrawal, and Sameer Singh, "A High-IIP3 Third-Order Elliptic Filter With Current-Efficient Feedforward-Compensated Opamps", IEEE Transactions on Circuit and System—II: Express Briefs, VOL. 58, NO. 4, APRIL 2011
- [16] Proakis, J. G. and Manolakis, D. G. 2007. Digital Signal Processing: Principles, Algorithms, and Applications. Pearson Education Ltd.
- [17] Sayan Ghosh, Debarati Kundu, Kaushik Suresh, Swagatam Das, and Ajith Abraham, "Design of Optimal Digital IIR Filters by Using a Bandwidth Adaptive Harmony Search Algorithm", 2009 World Congress on Nature & Biologically Inspired Computing (NaBIC 2009)
- [18] Nurhan Karaboga, "Digital IIR Filter Design Using Differential Evolution Algorithm", EURASIP Journal on Applied Signal Processing 2005:8, 1269–1276 ©2005 Hindawi Publishing Corporation.
- [19] Prof. SunayanaPatil, Pratik Pramod Bari, VivekAnandSakla, Rohit Ashok Shah, DharmilAshwin Shah, " Comparison of different realization techniques of IIR filters using system generator", International Journal of Engineering Research and Applications (IJERA) ISSN: 2248-9622 .
- [20]. Samarjeet Singh and Uma Sharma, "Matlab based Digital IIR filter design", International Journal of Electronics and Computer Science Engineering, Vol. 01, No. 01, ISSN 2277-1956, pp.74-83.
- [21]. Yaduvir Singh, Sweta tripathi and Manoj Pandey, " Analysis of Digital IIR filter with LabVIEW", International Journal of Computer Applications, Vol. 10, No. 06, 2010, pp.23-30.
- [22] Subhadeep Chakraborty, Subhasish Maitra, "Design and Determination of Optimum Coefficients of IIR Digital High pass Filter using Analog to Digital Mapping Technique", International Journal of Computer Applications (0975 – 8887) Volume 58– No.7, November 2012, pp 19-26. DOI: 10.5120/9295-3510
- [23] Subhadeep Chakraborty, "Design and Realization of IIR Digital Band Stop Filter Using Modified Analog to Digital Mapping Technique", International Journal of Science, Engineering and Technology Research (IJSETR), ISSN: 2278 – 7798 Volume 2, Issue 3, March 2013, pp 742-748.
- [24] Subhadeep Chakraborty, Abhirup Patra, "Determination of optimum coefficients of IIR Digital Butterworth Band-Stop Filter", International Journal of Advanced Research in Computer Engineering & Technology (IJARCET), ISSN: 2278 – 1323 Volume 2, Issue 2, February 2013, pp 719-725
- [25] Subhadeep Chakraborty, "Realization of High Order IIR Digital Bandstop Filter Using Domain Transfer Algorithm", International Journal of Advanced Research in Computer Science and Software Engineering, ISSN: 2277 128X, Volume 3, Issue 4, April 2013 , pp 790-798
- [26] Subhadeep Chakraborty, "Performance Analysis of IIR Digital Band Stop Filter", International Journal of Advanced Research in Computer Engineering & Technology (IJARCET), ISSN: 2278 – 1323, Volume 2, No 5, May 2013, pp 1749-1756

## BIOGRAPHIES



**Subhadeep Chakraborty**, born in 1986, is presently Lecturer in Technique Polytechnic Institute with 5 years of teaching experience. He received the B.Tech degree from Saroj Mohan Institute of Technology, WBUT, India and M.Tech degree from Kalyani Govt. Engineering College, WBUT, India in Electronics and Communication Engineering in 2008 and 2010. His primary research interest includes Digital Signal Processing, Embedded System and

Microprocessor, cloud computing, virtualization of Network and Swarm and Robotics.



**Abhishek Dey**, born in 1986, is presently Lecturer in Technique Polytechnic Institute with 3 years of teaching experience. He received the B.Tech degree WBUT, India and M.Tech degree from WBUT, India in Electronics and Communication Engineering in 2008 and 2010. His primary research interest includes Digital Signal Processing, Embedded System and Analog Electronics.



**Kushal Kumar Saha**, born in 1995, presently a student perusing Diploma Degree from Technique Polytechnic Institute in Electronics and Telecommunication Engineering in 3<sup>rd</sup> Year. His primary interests are Analog Electronics, Signal processing and Digital Filter.



**Nabanita Dutta**, born in 1994, presently a student perusing Diploma Degree from Technique Polytechnic Institute in Electronics and Telecommunication Engineering in 3<sup>rd</sup> Year. His primary interests are Analog Electronics, Signal processing and Digital Filter.